

# FALCON M20

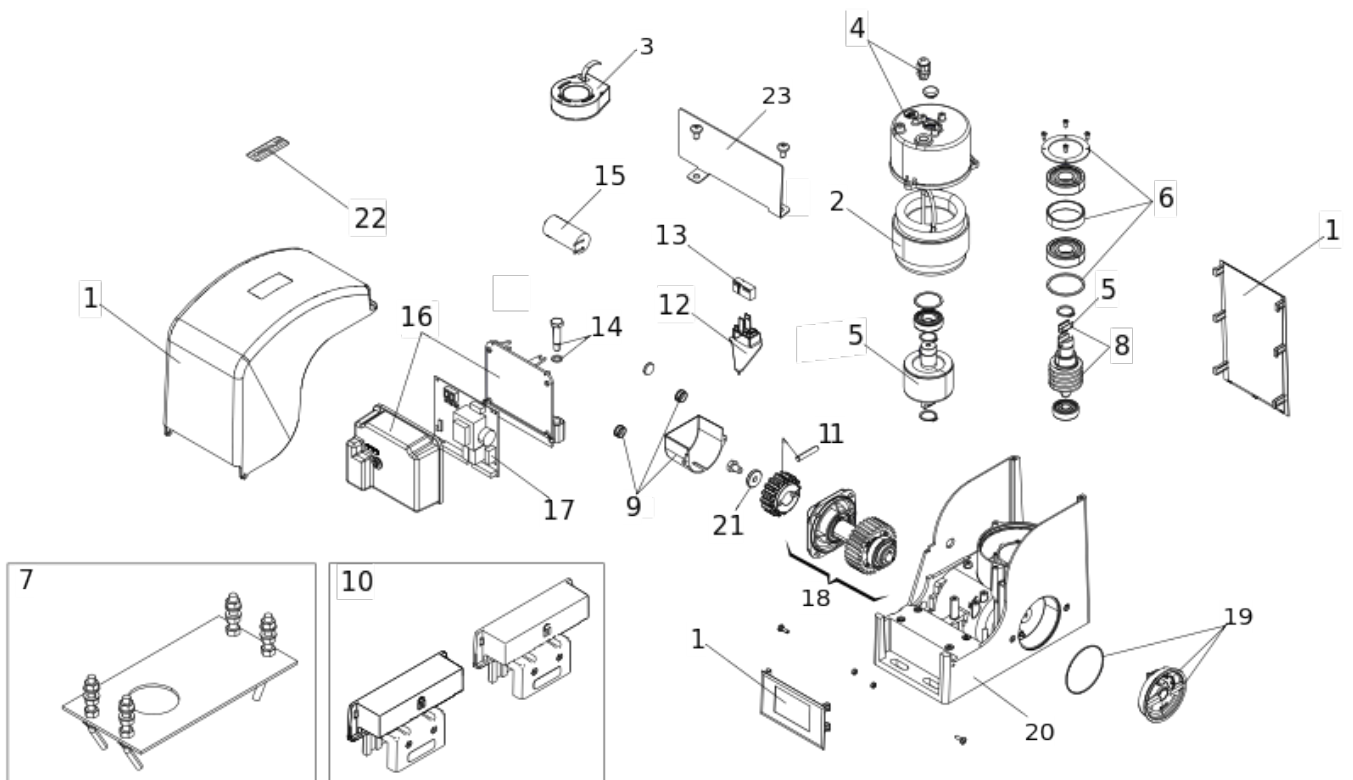

Pos.	Code	EAN	Quantity	Replacement code	Description	Salable
1	6020057	8055195016680	1		OUTER COVER	yes
2	6020064	8055195016734	1		STATOR •125 H50 4P 230V FOR FALCON 20	yes
3	6100013	8055195019230	1		ENCODER FOR SLIDING GATES	yes
4	6020055	8055195016666	1		CAP •125 H50 FOR FALCON 15-20	yes
5	6020062	8055195016710	1		ROTOR H50 FOR FALCON 15-20	no
6	6020058		1		SET OF 6 RINGS OF BEARINGS LOCKING	no
7	6020079	8055195016826	1		FOUNDATION PLATE FOR FALCON + NUTS AND T	yes
8	6020060	8055195016697	1		WORM SCREW	yes
9	6020056	8055195016673	1		HAND PROTECTION AND FORE CAPS	yes

Pos.	Code	EAN	Quantity	Replacement code	Description	Salable
10	6020670	8055195054668	1		MAGNETIC LIMIT SWITCHES GROUP BLIZZARD/C	yes
11	6020070	8055195016772	1		PINION Z16 M4 FOR FALCON 15-20	yes
12	6020315	8055195017625	1		REST FOR FALCON 14-15-20 SENSOR	yes
13	63001025	8055195032338	1		740/741/BLIZZARD REED SENSOR	yes
14	6020077	8055195016819	1		FASTENING SCREW FOR CONTROL BOA	yes
15	6020075	8055195016802	1		CONDENSER æF20 WITH TANG	yes
16	6020066	8055195016758	1		BOX FOR CONTROL BOARD	yes
17	202269	8055195006445	1		740D/SPRINT382 CONTROL BOARD	yes
18	6020068	8055195016765	1		SLOW SHAFT FOR FALCON 14-15-20	yes
19	6020065	8055195016741	1		RELEASING KNOB COMPLETE WITH LOCK	yes
20	6020073	8055195016789	1		BODY FOR SLIDING MOTOR	yes
21	00058P2154	8055195041705	1		BRASSES F0660	yes
22	63003203	8055195033915	1		MILORD-FALCON RESIN STICKER (5 PCS)	yes
23	6020673		1		SHIELD	yes